

DRAWING NO.  
AL 94040

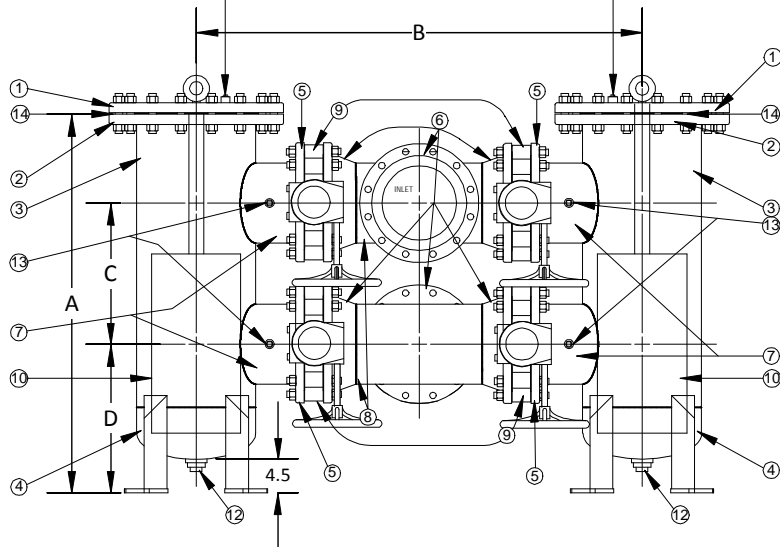
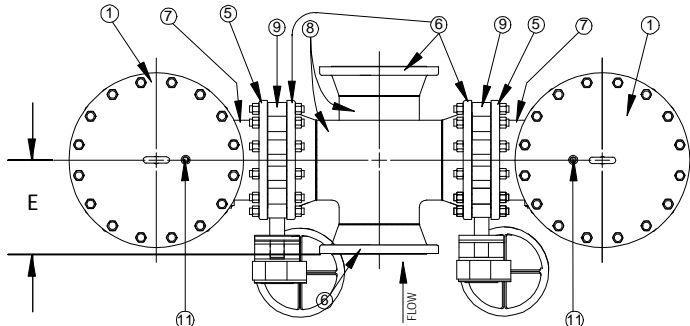

BODY PRESSURE & TEMPERATURE RATINGS - NON SHOCK	
NOM. RATING	8" to 24"
600# RFWN	1480 PSI @ 100°F

Product Number†	DIMENSIONS (in)								
	SIZE	A	B	C	D	E	Vent	Drain	Weight (lbs)
85RFFD-FCS125P34-FDB	8	53	55	20	17	12-1/2	1/2	2	3106
105RFFD-FCS125P34-FDB	10	61	70	23	20	15	1/2	2	5298
125RFFD-FCS125P34-FDB	12	70	77	26	24	16-3/8	1/2	2	7551
145RFFD-FCS125P34-FDB	14	72	82	27	24	17-3/4	1/2	2	10357
165RFFD-FCS125P34-FDB	16	80	91	30	27	19-1/4	1/2	2	14528
185RFFD-FCS125P34-FDB	18	84	96	33	27	21	1/2	2	17155
205RFFD-FCS125P34-FDB	20	89	101	35	28	22-3/4	1/2	2	23683
245RFFD-FCS125P34-FDB	24	107	111	40	30	25-1/4	1/2	2	29961

†See "Style FD Product Number Configuration" for additional options.

**PARTS LIST**

Item	Description	Material
1	600lb. Blind Covers	Carbon Steel (ASTM A 105)
2	600lb. Slip-On Flange	Carbon Steel (ASTM A 105)
3	Standard Weight Pipe	Carbon Steel (ASTM A 53)
4	Standard Weight End Cap	Carbon Steel (ASTM A 234, Grade WPB)
5	600lb. Slip-On Flange	Carbon Steel (ASTM A 105)
6	600lb. Weld-Neck Flange	Carbon Steel (ASTM A 105)
7	Standard Weight Pipe	Carbon Steel (ASTM A 53)
8	Standard Weight Tee	Carbon Steel (ASTM A 234, Grade WPB)
9	Butterfly Valves	Cast Iron Body / Ductile Iron Nickel Coated Discs - Buna-n Seats / Single Gear Operator
10	Baskets	Stainless Steel (304) - 1/8" Perforations
11	Air Vent	3000# NPT CS half Coupling (ASTM A 105)
12	Drain Connection	3000# NPT CS half Coupling (ASTM A 105)
13	Differential Pressure Taps	3000# NPT CS half Coupling (ASTM A 105)
14	Cover Gasket	Fiber

\*Buna-n o-ring good for temperatures up to 250°F. For higher temperatures, consult Factory.

 3400 CLEVELAND SKOKIE ILLINOIS	DRAWING NO. AL 94040
	PART NO.
DIMENSIONAL ASSEMBLY	SCALE: NTS
600Lb. Flange Style FSDPXF	DATE: 07/01/2011
Fabricated Duplex Basket Strainer	DR. BY DSF
MAT'L: Fabricated Carbon Steel	REQ. ---